

NEW ENGINES LONG BLOCK TECTOR F4A E3-E4-E5

WHAT IS A LONG BLOCK ?

- It is the heart of the engine

WHAT IS ITS COVERANGE RANGE ?

- 100% of the application

and then..4 or 6 Electrical Injectors are included!!

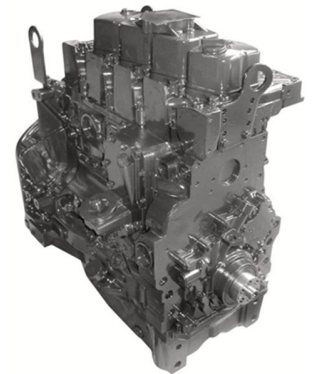

IVECO Engines parts are engineered specifically for Eurocargo / Buses vehicles and provide good as new functionality throughout the entire assembly

WHY A LONG BLOCK?

- **SIMPLE RANGE** : Few part numbers for an easy inventory management
 - ONLY 10 codes!!! ..and you will have on hand the full engine range for to repair your Eurocargo Truck or Arway Bus etc....with Tector engine
- **DOWN TIME FOR REPAIRING**: Installation time compared to an out-of-frame overhaul is 40 – 50% less
- **FLEXIBLE SOLUTION** : A simple versatile offer that satisfy customer needs
- **PRICE** : A short range offer tailored for your machinery at competitive price
- **OPPORTUNITY** : Capture new customer and enlarge the repair offer

IVECO Reman Engines Long Block
Now you can be confident your Machinery will be up to the task !

NEW ENGINES LONG BLOCK TECTOR F4A E3-E4-E5

BEST IN CLASS ON REMANUFACTURING INDUSTRIAL PROCESS

CNH Industrial Reman has invested in Engine Testing, we are committed to rigorously adhering to only the highest standards in remanufacturing throughout the entire process – from disassembly to testing and everything. Every engine in our facility means even greater accuracy in engine testing.



Fluorescent Magnetic Particle Inspection

Unlike some re-builders who inspect surfaces with a simple visual inspection, CNH Industrial Reman relies on Fluorescent Magnetic Particle Inspection throughout its remanufacturing process – a procedure that magnetizes components and applies a phosphorous solution over the part to reveal even the smallest surface flaws.

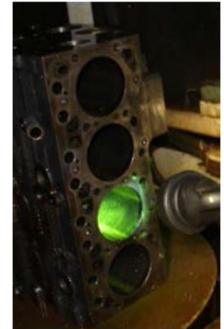

Air Decay Test

Another example of error proof technology in our test equipment is the air decay test.

1. CNH Industrial Reman Technicians block off all engine openings
2. The system is then pressurized to detect any fuel, oil and water leaks
3. Every CNH Industrial Reman engine undergoes this procedure to ensure engines are leak-free



Spin Test

CNH Industrial Reman has invested in a state-of-the-art spin test for long-block engines.

1. All torque and oil pressures are tested
2. Spin tests occur at variable speeds:

IVECO Reman Engines Long Block
A high standard of quality separates us from the competition

NEW ENGINES LONG BLOCK TECTOR F4A E3-E4-E5

PLUS OF IVECO LONG BLOCK REMAN

IVECO Long Block details



Read to fit

Please take your mind that some re-builders don't provide :

- A. Oil Pump
- B. Front cover, specific gaskets and seals must be adjusted in according to IVECO prescriptions
- C. Removal of the lower housing to allow the mounting of the front cover

A Competitor Long block details

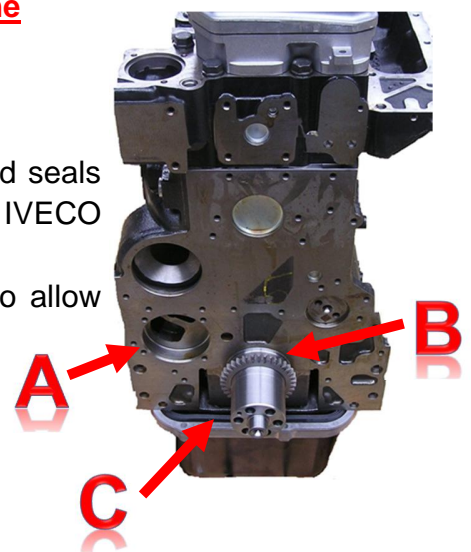

IVECO Long Block :

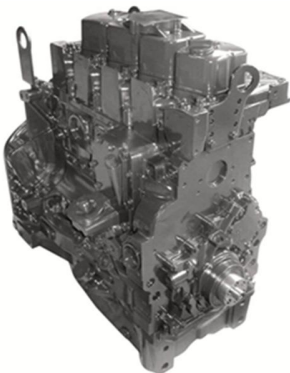

- It is a painted engine ensuring safe storage of oxidation
- It is always tested with Air Decay and Oil pressure Test
- All components are adjusted in according to IVECO prescriptions
- All components are genuine parts

An engine long block IVECO will save more than three hours in labour mounting and more than 1500 € of components

IVECO Reman Engines Long Block
A high standard of quality separates us from the competition

NEW ENGINES LONG BLOCK TECTOR F4A E3-E4-E5

PLUS OF IVECO LONG BLOCK REMAN

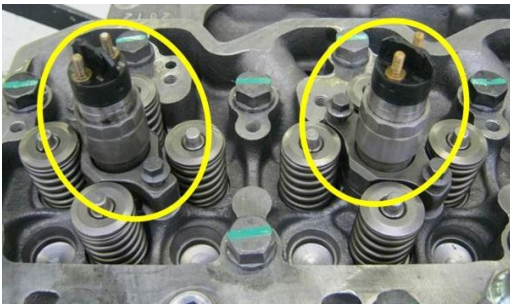

Electrical Injector

Unlike some re-builders who don't provide the electrical injectors; we provide the engine long block complete of four or six electrical injector so you are sure about their correct calibration

Rocker Arms Adjustment

They must be adjusted in according to IVECO prescriptions

If Incorrect Settings

Noisy engine or interference piston / valves or lack of Power



Wiring cable

For a sure calibration we mounted the connecting electrical wires on injector

If Incorrect connection

No injection on 1 or several cylinders, poor performance, incorrect rotation

IVECO Reman Engines Long Block
A high standard of quality separates us from the competition

NEW ENGINES LONG BLOCK TECTOR F4A E3-E4-E5

LONG BLOCK ENGINE INCLUDE

- Short block (*crankcase, *lower block and *crankshaft)
- Cylinder head (with valves, Rocker arms and springs)
- 100% new pistons, rings, bearings, seals, gaskets
- Camshaft and distribution gears
- Connecting rods
- Oil pump and Oil sump
- Heat exchanger
- Front and rear cover
- Electrical Injectors and wiring cable
- Front and rear covers



Injection of new components when they don't pass the Preliminary Quality Checks

THE VALUE of CNH ENGINE REMAN

- **INCREASED UPTIME** : It comes ready as drop-in assemblies, that means there is no need to waste time or labor hours with complicated rebuilds that result from unanticipated problems.
- **RELIABILITY** : It is engineered specifically for CNH machinery, minimizing risks and improving mechanical dependability
- **WARRANTY** : Take comfort; it has 12 Months Warranty; Parts Protection Guaranteed
- **PEACE of MIND, IT IS GOOD AS NEW** : Because an older core is machined and brought up-to-date with the latest changes and specifications, thereby improving the performance of older equipment.
- **TECHNICALLY SUPERIOR** : It is built by technicians who build hundreds of the same products each year, not just one per season or lifetime.
- **GREEN PRACTICES** : The CHN Reman is sustainable because it comes from a process of regeneration attentive to sustainability in fact the Remanufactured products are kept out of the waste stream longer, meaning that landfill space is preserved and air pollution is reduced from parts that would have had to be re-smelted or otherwise reprocess

USE IVECO Reman parts, MAKE the Environment Smile

NEW ENGINES LONG BLOCK TECTOR F4A E3-E4-E5

APPLICATION LIST

NR CYL.	EMIS	ENGINE TYPE	PN LONG BLOCK REMAN	AVAILABLE ON 2014	PN LONG BLOCK CORE	RANGE	MODELS
4	E3	F4AE0481_	2999812	NOV	2999811	TRUCK	EUROCARGO .E13 - .E15 - .E17
4	E3	F4AE0482B	2999808	***	2999807	BUS	EUROPOLIS
4	E4/5	F4AE3481_	2999810	NOV	2999809	TRUCK	EUROCARGO .E14 - .E16 - .E18
6	E3	F4AE0681_	2999818	NOV	2999817	TRUCK	EUROCARGO - EUROFIRE .E18 - .E21 - .E24 - .E28
6	E3	F4AE0681_	2999816	***	2999815	TRUCK	EUROCARGO (4X4) - EUROFIRE (4X4) .E18 - .E21 - .E24 - .E28
6	E3	F4AE0682_	2999814	***	2999813	BUS	MIDIRIDER .27 - EURORIDER .27
6	E4/5	F4AE3681_	2999820	NOV	2999819	TRUCK	EUROCARGO - EUROFIRE .E22 - .E25 - .E28 - .E30
6	E4/5	F4AE3681_	2999822	***	2999821	TRUCK	EUROCARGO(4X4) - EUROFIRE (4X4) .E25 - .E28
6	E4/5	F4AE3682A	2999824	***	2999823	BUS	ARWAY / CITELIS / CROSSWAY- RECREO / MIDIRIDER .30
6	E4/5	F4AE3682C-E	2999826	***	2999825	BUS	CROSSWAY- RECREO / EUROPOLIS .26 / HEULIEZ GX127

***: *will be produced on demand*

IVECO Reman Engines Long Block
A high standard of quality separates us from the competition